

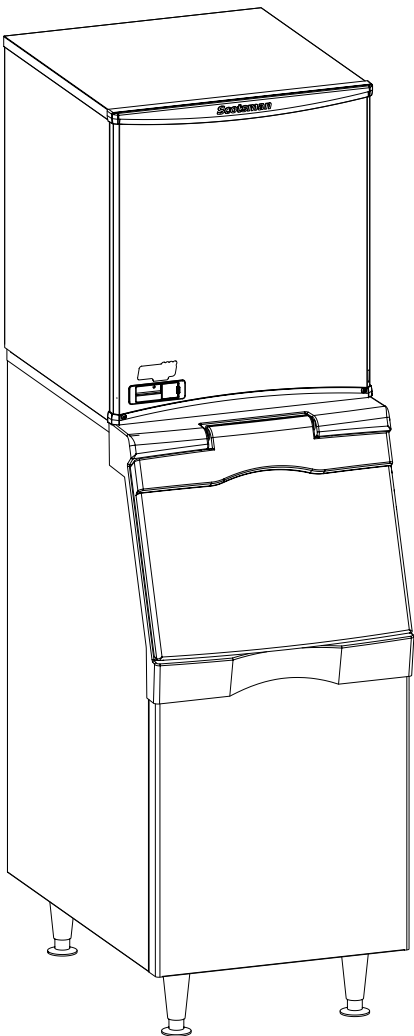

Installation and User's Manual for
Remote Low Side Modular Flaked and Nugget Ice
Machines

**Prodigy Plus E Series Models N0922L, N1322L,
N1322NCL, F1222L, F1522L and F1522NCL**



N0922L, N1322L, N1322NCL, F1222L, F1522L, F1522NCL

E Series Remote Low Side User Manual

Introduction

This ice machine is the result of years of experience with flaked and nugget ice machines. The latest in electronics has been coupled with the time tested Scotsman flaked ice system to provide reliable ice making and the features needed by customers. The features include simple conductivity water level sensing, evaporator clearing at shut down, photo-eye sensing bin control and the ability to add options.

Contents

Installation:	Page3
Location:	Page4
Cabinet Layout	Page5
Unpacking	Page6
Water	Page7
Electrical	Page8
Refrigeration	Page9
Final Check List.	Page10
Initial Start Up	Page11
Scale removal	Page12
Check Top Bearing	Page13
Bearing Service.	Page14
Options	Page15
Service Diagnosis	Page16
What to do before calling for service	Page17

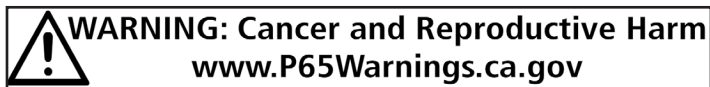

N0922L, N1322L, N1322NCL, F1222L, F1522L, F1522NCL

E Series Remote Low Side User Manual Installation:

This machine is designed to be used indoors, in a controlled environment. Operation outside the limits listed here will void the warranty.

Air temperature limits

	Minimum	Maximum
Ice maker	50°F.	100°F.

Water temperature limits

	Minimum	Maximum
All models	40°F.	100°F.

Water pressure limits (potable)

	Minimum	Maximum
All models	20 psi	80 psi

Voltage limits

	Minimum	Maximum
115 volt	104	126

Minimum conductivity (RO water)

- 10 microSiemens / CM

Water Quality (ice making circuit)

- Potable

The quality of the water supplied to the ice machine will have an impact on the time between cleanings and ultimately on the life of the product. Water can contain impurities either in suspension or in solution. Suspended solids can be filtered out. In solution or dissolved solids cannot be filtered, they must be diluted or treated. Water filters are recommended to remove suspended solids. Some filters have treatment in them for suspended solids. Check with a water treatment service for a recommendation.

RO water. This machine can be supplied with Reverse Osmosis water, but the water conductivity must be no less than 10 microSiemens/cm.

Potential for Airborne Contamination

Installing an ice machine near a source of yeast or similar material can result in the need for more frequent sanitation cleanings due to the tendency of these materials to contaminate the machine.

Most water filters remove chlorine from the water supply to the machine which contributes to this situation. Testing has shown that using a filter that does not remove chlorine, such as the Scotsman Aqua Patrol, will greatly improve this situation.

Warranty Information

The warranty statement for this product is provided separately from this manual. Refer to it for applicable coverage. In general warranty covers defects in material or workmanship. It does not cover maintenance, corrections to installations, or situations when the machine is operated in circumstances that exceed the limitations printed above.

N0922L, N1322L, N1322NCL, F1222L, F1522L, F1522NCL

E Series Remote Low Side User Manual

Location:

While the machine will operate satisfactorily within the air and water temperature limits, it will operate more efficiently when those temperatures are nearer the lower limits. Avoid locations that are hot, dusty, greasy or confined.

Options

The standard machine will make ice until ice fills the bin and blocks an infrared light beam inside the bottom of the machine. A field installed kit is available to adjust the ice level lower. That kit number is KVS.

The standard controller has excellent diagnostic capabilities and communicates to the user through the AutoAlert light panel, seen through the front panel. There is a field installed kit that can log data and provide additional information when the front panel is removed. That kit number is KSBU. A similar kit adds network connectivity, and its number is KSB-NU.

Bin compatibility

All models are the same width: 22 inches. All models are the same depth: 24 inches.

Bin & adapter list:

- B322S – no adapter needed
- B330P – Use KBT27
- B530P – Use KBT27
- B530S – Use KBT27
- B842S – Use KBT39
- B948S - Use KBT38 for a single unit
- B948S – Use KBT38-2X for two units side by side

BH1100, BH1300 and BH1600 upright bins include filler panels to accommodate a single 22 inch wide flake or nugget ice machine. No adapter is needed.

Dispenser compatibility

Only nugget ice models may be used with ice dispensers. Flaked ice is not dispensable.

- ID150 – use KBT42 and KDIL-PN-150; includes KVS, KNUGDIV and R629088514
- ID200 – use KBT43 and KNUGDIV and KVS
- ID250 – use KBT43 and KNUGDIV and KVS

See sales literature for other brand model ice and beverage dispenser applications.

Other Bins & Applications:

Note the drop zone and ultrasonic sensor locations in the illustrations on the next page.

Line Set

NRTE45 is a non-precharged tubing kit that contains a 45 foot 3/8" liquid line and a 45 foot 5/8" suction line. Tubes are supplied nitrogen charged and capped.

Scotsman ice systems are designed and manufactured with the highest regard for safety and performance.

Scotsman assumes no liability of responsibility of any kind for products manufactured by Scotsman that have been altered in any way, including the use of any part and/or other components not specifically approved by Scotsman.

Scotsman reserves the right to make design changes and/or improvements at any time. Specifications and design are subject to change without notice.

N0922L, N1322L, N1322NCL, F1222L, F1522L, F1522NCL

E Series Remote Low Side User Manual Cabinet Layout

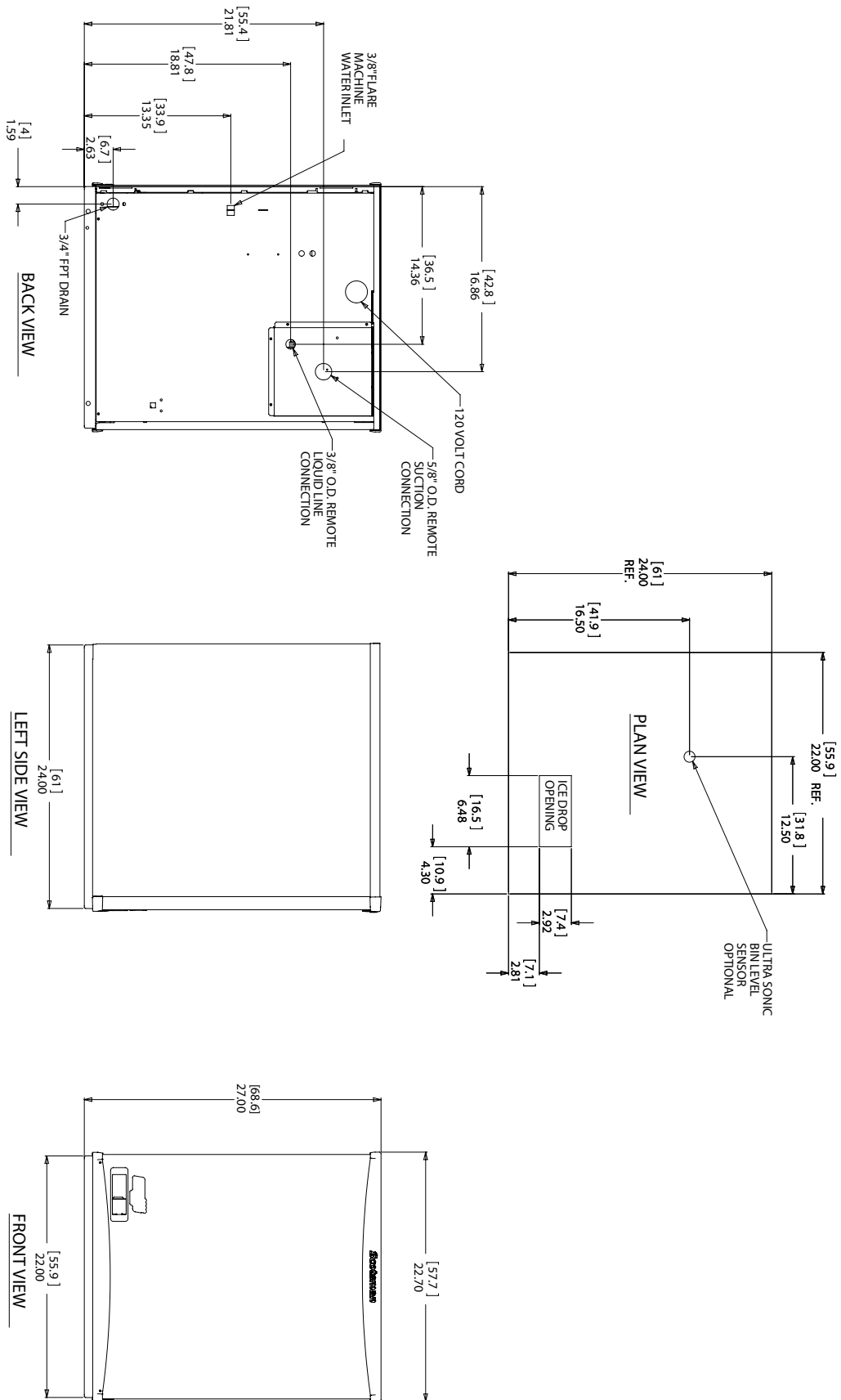

N0922L, N1322L, N1322NCL, F1222L, F1522L, F1522NCL

E Series Remote Low Side User Manual

Unpacking

Remove the carton from the skid. Check for hidden freight damage, notify the carrier immediately if any is found. Retain the carton for the carrier's inspection.

The machine is not bolted to the skid. If strapped remove the strap.

Place on Bin or Dispenser

If reusing an existing bin, be sure that the bin is in good shape and that the gasket tape on the top is not torn up. Water leaks, not covered by warranty, could result from a poor sealing surface. Because this is a remote low side, a new bin is recommended due to the high cost to the user of replacing an old bin when a remote system is on top.

Install the correct adapter, following the directions supplied with that adapter.

Hoist the machine onto the adapter.

Note: The machine is heavy! Use of a mechanical lift is recommended.

Position the machine on the bin or adapter. Secure with straps from the hardware bag packed with the machine, or those supplied with the adapter.

Remove any plastic covering the stainless steel panels.

Remove any packaging, such as tape or foam blocks, that may be near the gear reducer or ice chute.

Level the bin and ice machine front to back and left to right by using the bin leg levelers.

Panel Removal

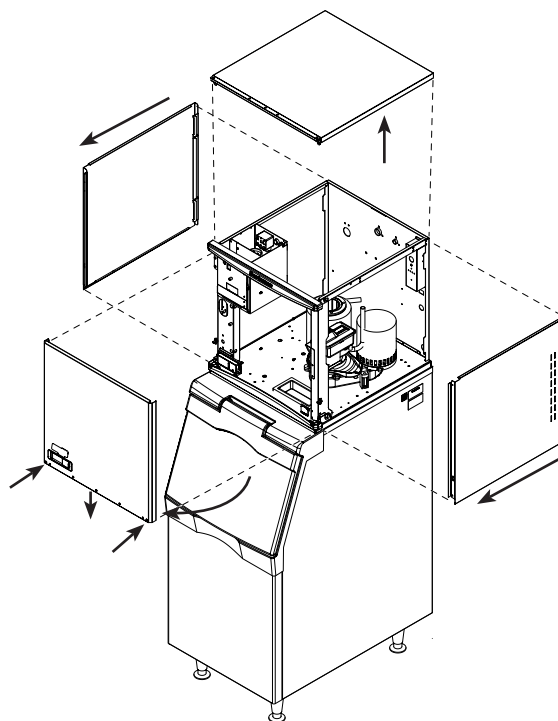

1. Locate and loosen the two screws at the bottom edge of the front panel.
2. Pull the front panel out at the bottom until it clears the bin.
3. Lower the front panel down and off the machine.
4. Remove two screws at the front of the top panel. Lift up the front of the top panel, push the top panel back an inch, then lift to remove.
5. Locate and loosen the screw holding each side panel to the base. Left side panel also has a screw holding it to the control box.
6. Pull the side panel forward to release it from the back panel.

N0922L, N1322L, N1322NCL, F1222L, F1522L, F1522NCL

E Series Remote Low Side User Manual Water

The water supply for ice making must be cold, potable water. There is a single 3/8" male flare potable water connection on the back panel.

Backflow

The design of the float valve and reservoir prevents potable water backflow by means of a 1" air gap between the reservoir's maximum water level and the float valve water inlet orifice.

Drain

There is one 3/4" FPT condensate drain fitting at the back of the cabinet.

Tubing

Connect the potable water supply to the potable water fitting, 3/8" OD copper tubing or the equivalent is recommended.

Connect the drain tube to the condensate drain fitting. Vent this drain tube.

Do not Tee ice machine drains into the drain tube from the ice storage bin or dispenser. Back ups could contaminate and / or melt the ice in the bin or dispenser.

Follow all local and national codes for tubing, traps and air gaps.

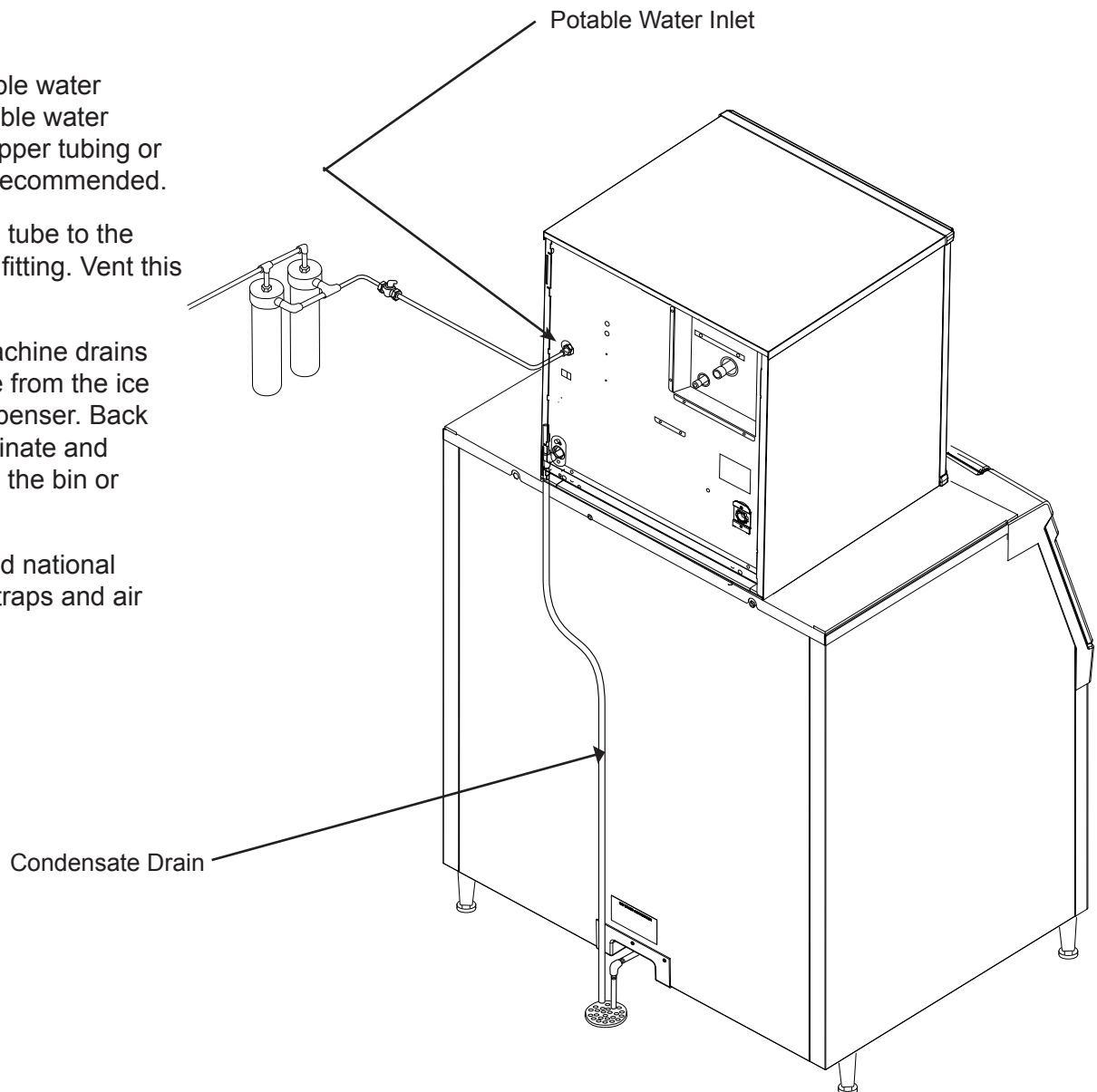

N0922L, N1322L, N1322NCL, F1222L, F1522L, F1522NCL

E Series Remote Low Side User Manual Electrical

The machine includes a power cord, connect to the proper power supply. A separate circuit is recommended to avoid unintended shut downs.

If a dedicated condensing unit is connected to this machine, it will have a separate power supply.

Do not use an extension cord.

Follow all local and national codes.

Model	Dimensions w" x d" x h"	Voltage Volts/Hz/Phase	Min Circuit Ampacity	Max Fuse Size (cord connected)
All	22 x 24 x 27	115/60/1	5.8	15

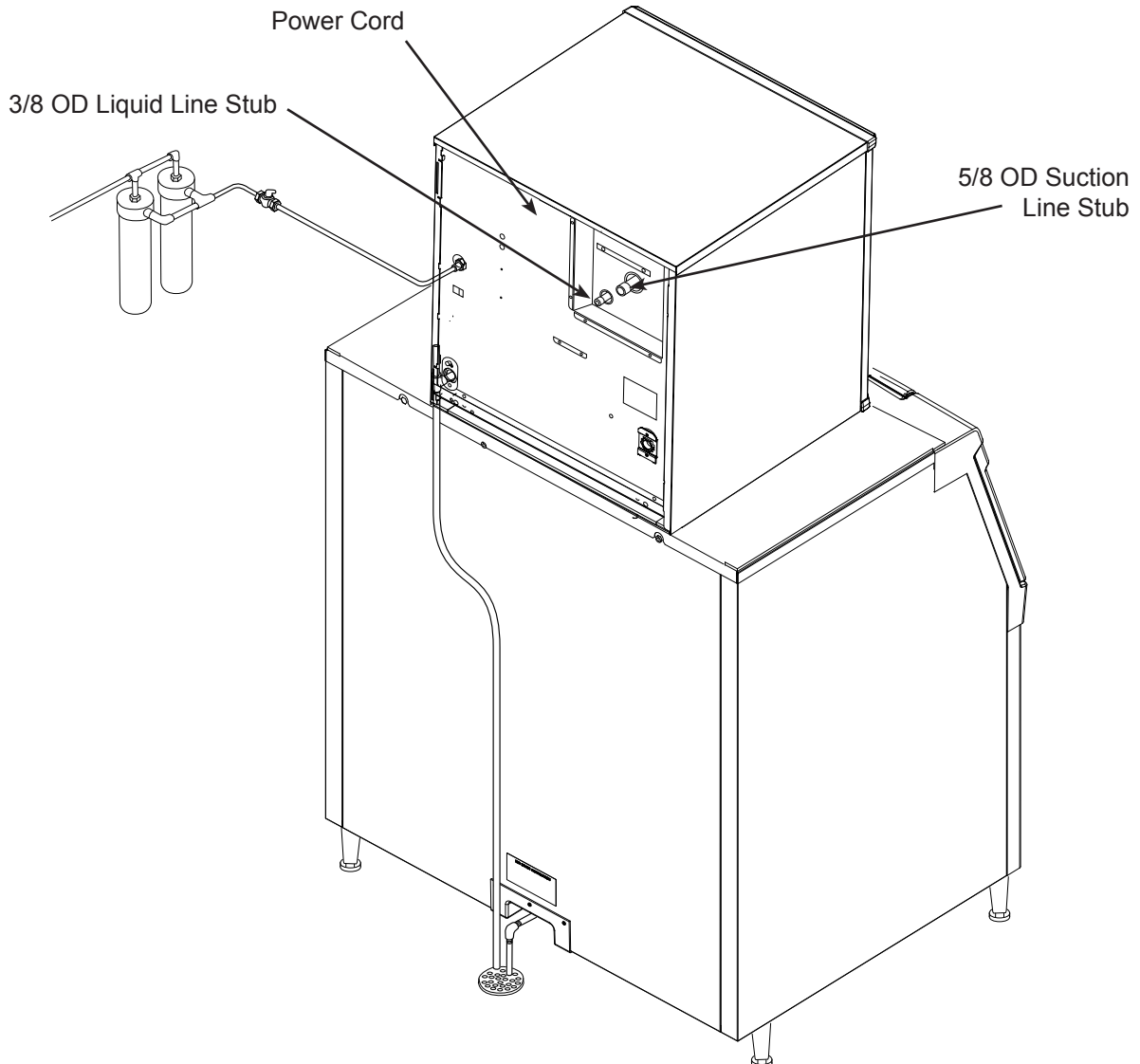

N0922L, N1322L, N1322NCL, F1222L, F1522L, F1522NCL

E Series Remote Low Side User Manual Refrigeration

BTUH Capacity Requirements

Model	BTUH
N0922L & F1222L	5,000
N1322L, F1522L, N1322NCL & F1522NCL	7,200

Condensing Units Used and Holding Charge

Unit	Condensing Unit	Holding Charge
N0922L F1222L	NME954-RHS-A/C or rack	R404A
N1322L F1522L	None - rack only	R404A
N1322NCL F1522NCL	None - rack only	Nitrogen

Remote low side models require connection to a dedicated condensing unit or a rack system.

Recommended Tubing from Head to Condensing Unit

- Suction Line: 5/8" OD
- Liquid Line: 3/8" OD

Distance limits:

- Maximum distance between dedicated condensing unit and head: 75 feet.
- Condensing Unit Elevation over Ice Making Section: 35 feet.

Note: Elevations greater than 20 feet require installation of a suction line trap at the 10 foot mark.

Ice Making Section

- Elevation over Condensing Unit: 15 feet.

Line Routing:

- Allowed: One rise after a drop.
- Allowed: One drop after a rise.
- Not Allowed: More than one rise after a drop
- Not Allowed: More than one drop after a rise

Roof Attachment

Install and attach the remote condensing unit to the roof of the building, using the methods and practices of construction that conform to the local building codes, including having a roofing contractor secure the condenser to the roof.

Refrigeration Installation:

Connections

The liquid and suction fittings on the back of the cabinet are stubs. The liquid line size is 3/8" OD. The suction line size is 5/8" OD.

1. On R-404A models recover the R404A holding charge or on the "NCL" units vent Nitrogen
2. Cut the stubs off.
3. Braze line set tubing to each fitting. Sweep with dry nitrogen while brazing.
4. Dedicated condensing unit: Evacuate complete system to 50 microns.
5. Open the ball valves.

Rack: The skills of a refrigeration technician are required to connect the ice machine to the building's refrigeration system.

Notes:

- R-404A models: 10 ounces of R-404A refrigerant is in the system as a holding charge.
- Be sure the liquid connection is NOT in series with another liquid line valve.
- Local Codes must be observed.

Dedicated condensing unit: Add refrigerant charge. Recommended starting field charge:

- N0922L or F1222L: 8 lb R-404A
- N1322L or F1522L: n/a - rack only
- N1322NCL or F1522NCL: n/a - rack only

N0922L, N1322L, N1322NCL, F1222L, F1522L, F1522NCL

E Series Remote Low Side User Manual

Final Check List

After Connections

1. Wash out the bin. If desired, the interior of the bin could be sanitized.
2. Locate the ice scoop (if supplied) and have it available for use when needed.

Final Check List:

1. Is the unit located indoors in a controlled environment?
2. Is the unit located where it can receive adequate cooling air?
3. Has the correct electrical power been supplied to the machine?
4. Have all the water supply connections been made?
5. Have all the drain connections been made?
6. Has the unit been leveled?
7. Have all unpacking materials and tape been removed?
8. Is the correct switch bezel installed in the trim strip?
9. Is the water pressure adequate?
10. Have the drain connections been checked for leaks?
11. Has the bin interior been wiped clean or sanitized?
12. Have any water filter cartridges been replaced?
13. Have all required kits and adapters been properly installed?
14. Has the ice machine been properly connected to the condensing unit or rack?

Control Operation

Use and Operation

Once started, the ice machine will automatically make ice until the bin or dispenser is full of ice.

When ice level drops, the ice machine will resume making ice.

Caution: Do not place anything on top of the ice machine, including the ice scoop. Debris and moisture from objects on top of the machine can work their way into the cabinet and cause serious damage. Damage caused by foreign material is not covered by warranty.

There are four indicator lights at the front of the machine that provide information on the condition of the machine.

Indicator Lights:

- Power
- Status
- Water
- De-scale & Sanitize

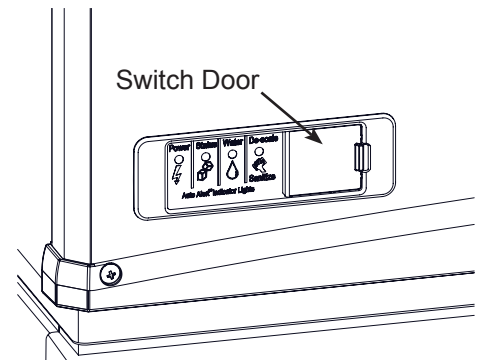

Under the door are two switches – On and Off. To switch the machine OFF, push and release the Off button. The machine will shut off at the end of the next cycle.

To switch the machine ON, push and release the On button. The machine will go through a start up process and then resume ice making.

N0922L, N1322L, N1322NCL, F1222L, F1522L, F1522NCL

E Series Remote Low Side User Manual Initial Start Up

1. Turn the water supply on.
2. Switch the electrical power on. Confirm voltage is correct for the model.
3. Push and release the On button. The machine will start up in about two minutes.

The liquid line valve will open and liquid refrigerant will flow into the machine. For the units connected to a dedicated condensing unit, the resulting increase in suction pressure will start the condensing unit and the condensing unit will begin discharging warm air from the remote condenser. After about 5 minutes, ice will begin to drop into the bin or dispenser.

4. Check the machine for unusual rattles.
5. Tighten any loose screws, be sure no wires are rubbing moving parts. Check for tubes that rub.
6. Check suction pressure and adjust the EPR setting for optimum performance.

Note: As shipped the EPR valve should maintain low side pressure at about 36 PSIG + or - 2 PSIG.

7. Check superheat and if needed adjust to 12°F, + or - a few degrees

Note: Machines will operate and make ice at the factory EPR setting for optimum performance, adjust the EPR to the settings in the chart below:

Model Number	Ice Head EPR Setting	Superheat Setting
N0922L / F1222L	30 PSIG	12°F, + or - a few degrees
N1322L / F1522L	26 PSIG	12°F, + or - a few degrees
N1322NCL / F1522NCL	26 PSIG	12°F, + or - a few degrees

8. Fill out the warranty registration form and either file it on line or mail it.
9. Notify the user of the maintenance requirements and whom to call for service.

Maintenance

This ice machine needs five types of maintenance:

- Remote condensing units need their condenser coils

cleaned regularly.

- All models need scale removed from the water system.
- All models require regular sanitization.
- All models require sensor cleaning.
- All models require a top bearing check.

Maintenance Frequency:

Scale removal. At least twice a year, in some water conditions it might be every 3 months. The yellow De-Scale & Sanitize light will switch on after a set period of time as a reminder. The default time period is 6 months of power up time. There are 4 available time period intervals: 1 year, 0 or disabled, 6 months or 4 months.

Sanitizing: Every time the scale is removed or as often as needed to maintain a sanitary unit.

Sensor Cleaning: Every time the scale is removed.

Top bearing check: At least twice a year or every time the scale is removed.

Maintenance: Remote air cooled condenser

The condenser fins will occasionally need to be cleaned of leaves, grease or other dirt. Check the coil every time the ice machine is cleaned.

Maintenance: Exterior Panels

The front and side panels are durable stainless steel. Fingerprints, dust and grease will require cleaning with a good quality stainless steel cleaner

Note: If using a sanitizer or a cleaner that contains chlorine on the panels, after use be sure to wash the panels with clean water to remove chlorine residue.

Maintenance: Water filters

If the machine has been connected to water filters, check the cartridges for the date they were replaced or for the pressure on the gauge. Change cartridges if they've been installed more than 6 months or if the pressure drops too much during ice making



N0922L, N1322L, N1322NCL, F1222L, F1522L, F1522NCL

E Series Remote Low Side User Manual

Scale removal

Note: Following this procedure will reset the de-scale and sanitize light.

1. Remove front panel.
2. Push and release the Off button.
3. Remove ice from bin or dispenser.
4. Turn the water supply to the ice machine OFF.
5. Drain the water and evaporator by disconnecting the leg of the hose connected to the water sensor and draining it into the bin. Return the hose to its original position.
6. Remove the water reservoir cover.
7. Mix a solution of 8 ounces of Scotsman Clear One Scale Remover and 3 quarts of 95-115 degree F. potable water.

 CAUTION	Scotsman Ice Machine Cleaner contains acids. These compounds may cause burns. If swallowed, DO NOT induce vomiting. Give large amounts of water or milk. Call Physician immediately. In case of external contact, flush with water. KEEP OUT OF THE REACH OF CHILDREN
	

8. Pour the scale remover solution into the reservoir. Use a small cup for pouring.
9. Push and release the Clean button: the auger drive motor and light are on, C is displayed and the De-scale light blinks. After 20 minutes the compressor will start.
10. Operate the machine and pour the scale remover into the reservoir until it is all gone. Keep the reservoir full. When all the scale remover solution has been used, turn the water supply back on. After 20 minutes of ice making the compressor and auger motor will shut off.
11. Turn the water supply to the ice machine OFF
12. Drain the water reservoir and evaporator by disconnecting the leg of the hose connected to the water sensor and draining it into the bin or a bucket. Return the hose to its original position.

Discard or melt all ice made during the previous step.

13. To sanitize the water system, mix a locally approved sanitizing solution. An example of a sanitizing solution is mixing one ounce of liquid household bleach and two gallons of 95 – 115 degree F. water.
14. Pour the sanitizing solution into the reservoir.
15. Push and release the On button.
16. Switch the water supply to the ice machine on.
17. Operate the machine for 20 minutes.
18. Push and release the Off button.
19. Wash the reservoir cover in the remaining sanitizing solution.
20. Return the reservoir cover to its normal position.
21. Melt or discard all ice made during the sanitizing process.
22. Wash the inside of the ice storage bin with the sanitizing solution.
23. Push and release the On button.
24. Return the front panel to its original position and secure with the original screws.

E Series Remote Low Side User Manual
Check Top Bearing

This task should only be done by a qualified service technician

The bearing in the breaker should be checked at least two times per year.

Check the bearing by:

1. Removing the bail clamp and ice chute cover

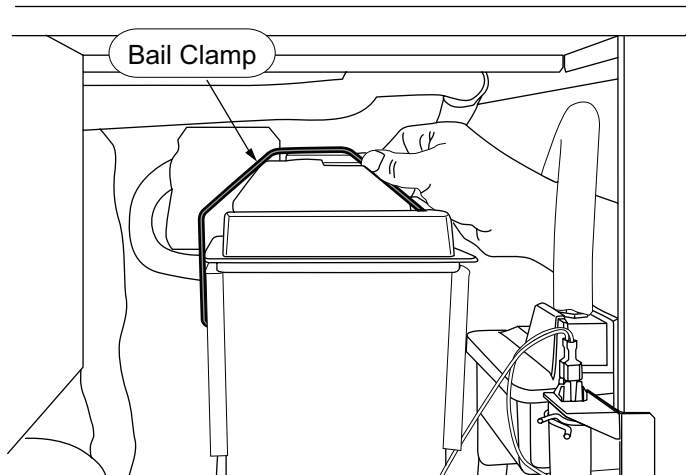

2. Unscrewing the ice sweep

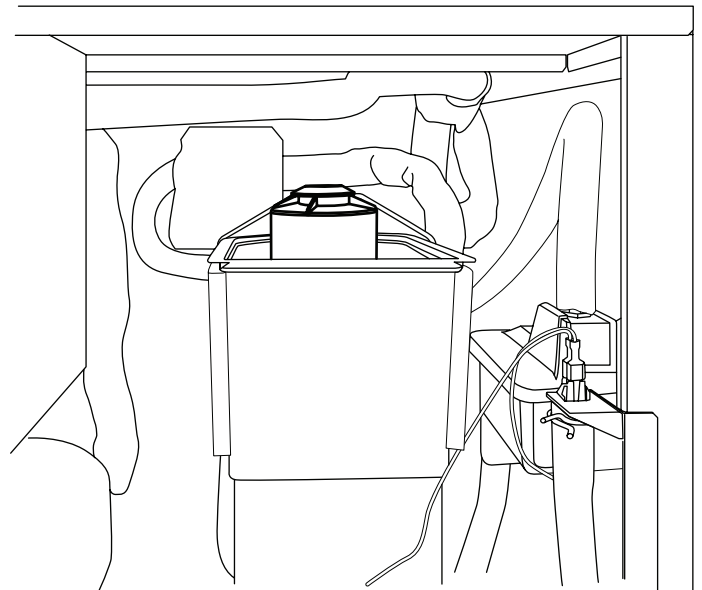
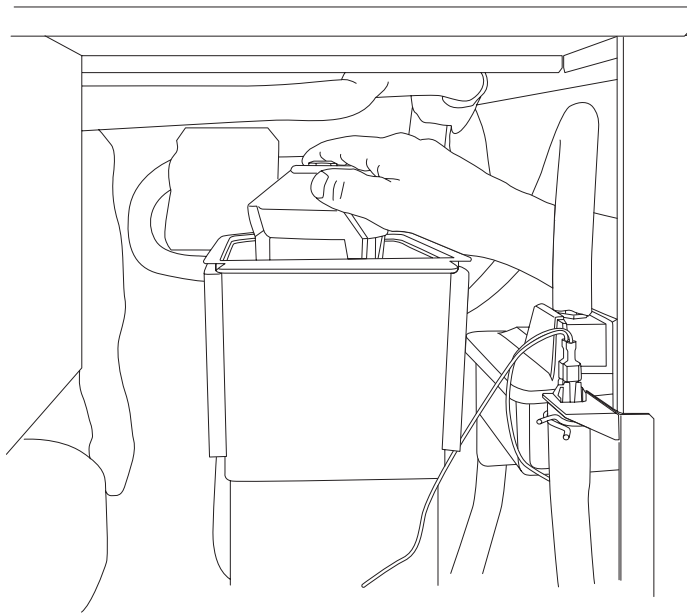

3. Removing the water shed & unscrewing the breaker cover (left hand threads).

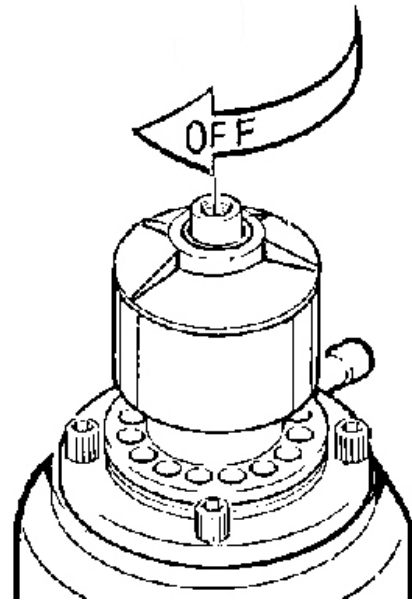

4. Inspect the top of the bearing. When new the grease is white, over time some gray will appear over the rollers, that is normal. Add grease to replace gray grease or if gaps between rollers are visible. If grease is watery, all gray or rust is visible, have the bearing replaced. See the next page for more information.

Note: When checking the top bearing, always inspect the drip pan for water seal leaks. If water is present in the drip pan, service the water seal and check the gear reducer's lubricant. See the next page.

N0922L, N1322L, N1322NCL, F1222L, F1522L, F1522NCL

E Series Remote Low Side User Manual Bearing Service

This task should only be done by a qualified service technician

If the bearing only needs grease, or to confirm the quality of the grease low in the bearing, inject grease into the lower part of the bearing using Scotsman

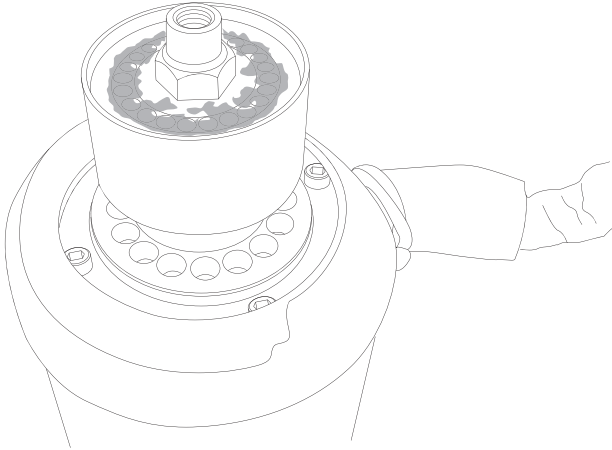

grease needle pn 02-3559-01 and Scotsman bearing grease cartridge, pn A36808-001. Be sure to inject grease evenly and thoroughly.

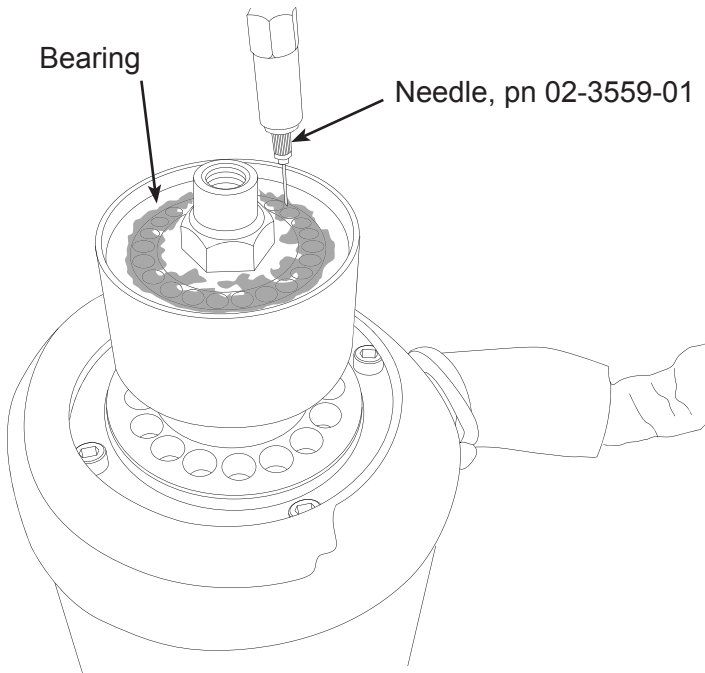

If the grease is uniformly white, no further action is needed. If very gray, rusty, wet or has any embedded metal, have the bearing replaced.

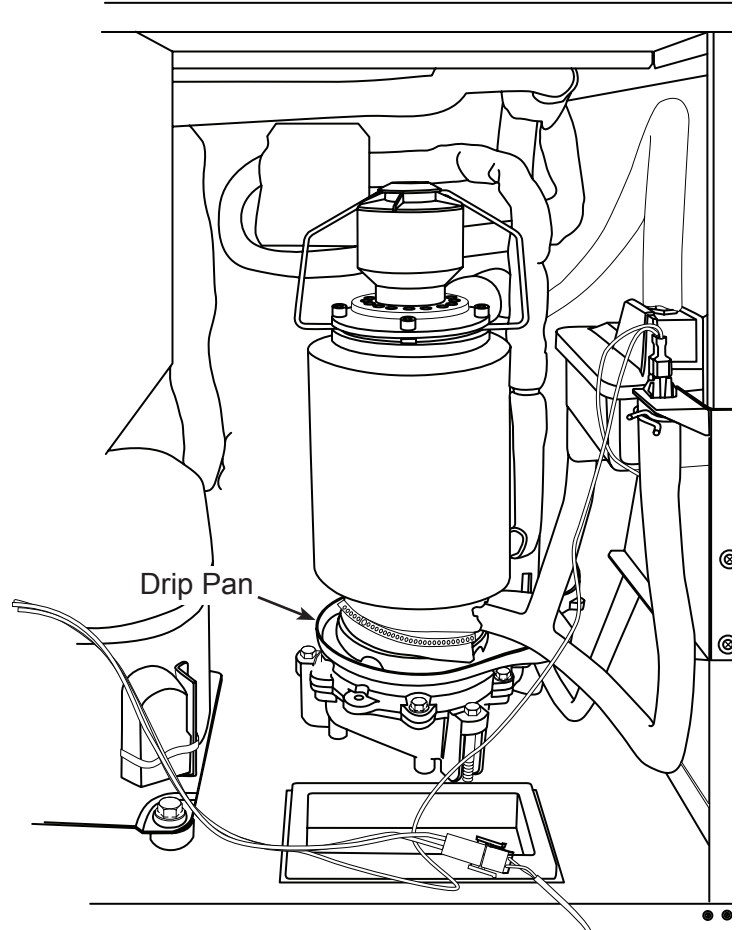

Check Drip Pan For Water

Change De-Scale Notification Interval

This feature is accessible only from standby
(Status Light Off).

1. Press and hold Clean button for 3 seconds.

Starts the Time to Clean Adjustment State and displays the current time to clean setting.

2. Press the clean button repeatedly to cycle through the 4 possible settings:

- 1 year (8760 hours)
- 0 (disabled)
- 4 months (2920 hrs)
- 6 months (4380 hours) (default)

E Series Remote Low Side User Manual
Options

Vari-Smart

Optional adjustable ice level control (KVS)



Dispenser applications -

Nugget ice only:

Set the adjustment knob to either the first or second position CW after the maximum fill position.

When this option is present there is an adjustment post and an additional indicator light to the right of the four indicator lights mentioned earlier. The ultrasonic ice level control allows the user to control the point that the ice machine will stop making ice before the bin or dispenser is full. Reasons for this include:

- Seasonal changes in ice used
- Planning to sanitize the bin
- Faster turnover for fresher ice
- Certain dispenser applications where maximum ice level is not desired

There are several positions the ice level can be set to, including Off (knob and label indicators lined up), where it fills the bin until the standard bin control shuts the machine off. See the kit's instructions for complete details.

Rotate the adjustment post to the desired ice level. The machine will fill up to that level and when it shuts off the indicator light next to the adjustment post will be On.



Note: The maximum fill position is when the arrow on the knob points to the arrow on the label

N0922L, N1322L, N1322NCL, F1222L, F1522L, F1522NCL

E Series Remote Low Side User Manual

Service Diagnosis

Symptom	Probable Cause	Possible Correction	
No ice	No power	Check that ice machine and condensing unit, if used, both have power. If power light is out, check transformer.	
	Code 3: No water	Restore water	
	Status light is off	Push and release ON switch	
	Code 1: No ice sensed		Check for ice flow down chute. if very slow or no ice being made, check water inlet tubing for restriction; check for condensing unit or refrigeration system failure
			Check auger motor for power, if no power, check controller component indicator light. If there is power to the motor, check motor windings
	Code 2: Auger motor draws too many amps, controller shuts unit off.		Check that liquid line valve shuts off tightly
			Check for damage to gear reducer or auger bearings.
	Bin Eyes Blocked light is On		Ice is in the chute.
			No ice in the chute. Check position of sensors, check sensors for scale build up
	Everything is in operation, but no refrigeration effect		Check liquid line valve
Check condensing unit			
Check TXV			
Check refrigerant charge			
Low ice making capacity	Scale build up	Remove scale from evaporator and water system	
	Restricted water supply to evaporator	Squeeze hose, if bubbles appear revise hose and reservoir	
	Suction tubing kinked	Check suction tubing	
	Expansion valve superheat incorrect	Check superheat	

N0922L, N1322L, N1322NCL, F1222L, F1522L, F1522NCL

F Series Remote Low Side User Manual What to do before calling for service

Normal Operation

Ice

The machine will make either flaked or nugget ice, depending upon the model. The ice will be produced continuously until the bin is full.

Heat

Most heat is exhausted at the remote condensing unit or at the rack; the ice machine should not generate significant heat.

Noise

The ice machine will make noise when it is in ice making mode. The gear reducer will produce sound. Some ice making noise could also occur. These noises are all normal for this machine.

Reasons the machine might shut itself off:

- Lack of water.
- Does not make ice
- Auger motor overloaded
- Controller self test failure.

Check the following:

1. Has the water supply to the ice machine or building been shut off? If yes, the ice machine will automatically restart within minutes after water begins to flow to it.

2. Has power been shut off to the ice machine? If yes, the ice machine will automatically restart when

power is restored.

3. Has someone shut the power off to the remote condensing unit while the ice machine still had power? If yes, the ice machine may need to be manually reset.

To Manually Reset the machine.

- Open the switch door
- Push and release the Off button.
- Push and release the On button.

To Shut the Machine Off:

1. Push and hold the Off button for 3 seconds or until the machine stops

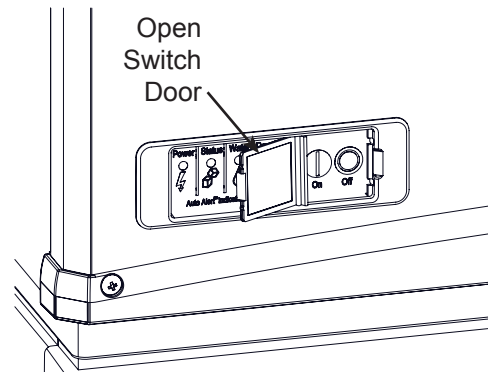

Light Actions	Indicator Lights & Their Meanings			
	Power	Status	Water	De-Scale & Sanitize
Steady Green	Normal	Normal	-	-
Blinking Green	Self Test Failure	Switching on or off. When Smart-Board used, machine attention recommended.	-	-
Blinking Red	-	Diagnostic shut down	Lack of water	-
Yellow	-	-	-	Time to descale and sanitize
Blinking Yellow	-	-	-	In Cleaning Mode
Light Off	No power	Switched to Off	Normal	Normal

SCOTSMAN ICE SYSTEMS

101 Corporate Woods Parkway

Vernon Hills, IL 60061

800-726-8762

www.scotsman-ice.com